

WIRELESS HYDRONIC DIFFERENTIAL PRESSURE MANOMETER

Liquid and Gas Pressure Measurement, $\pm 2\%$ of Reading Accuracy

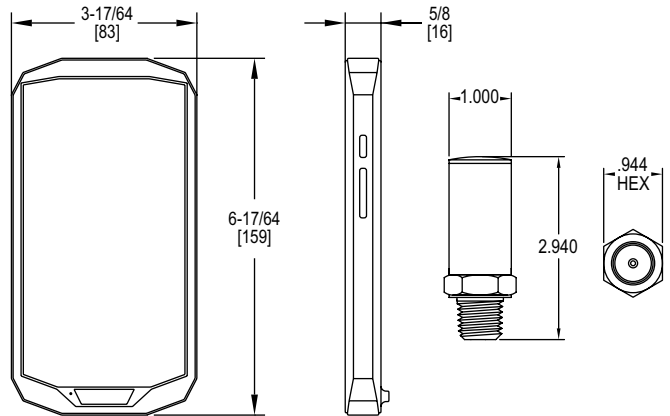

DEALER DESIGN
AWARDS



Series 490W Wireless Hydronic Differential Pressure Manometer is the most accurate and easy to operate manometer on the market. By using wireless transducers and a versatile handheld, a single operator can monitor and balance a hydronic system in less time than traditional hydronic balancers. The Series 490W utilizes mobile technology to communicate via a Bluetooth connection with the transducers to monitor differential pressure and flow on up to three different valves. Being wireless means there are no hoses to carry, snag on equipment or needing to be drained. The 490W includes the Dwyer Hydronic Application Software that contains valve charts for numerous manufacturers, which converts differential pressure to flow directly on the screen.

FEATURES/BENEFITS

- Rugged weatherproof handheld housing withstands 1.5 meter drop test
- Wireless measurement of differential pressure, single pressure and air flow
- Bluetooth direct wireless communication provides range up to 65 ft (19.8 m)
- The ergonomic design is much lighter and easier to work with, providing greater maneuverability and quick install setup

APPLICATIONS

- Refrigerant pressure testing
- Hydronic valve balancing
- Measure pressure drop across pumps
- Measure pressure drop across chiller and coils for freeze protection

SPECIFICATIONS

Wireless Distance: Up to 65' (19.8 m).
Service: Compatible gases and liquids.
Wetted Materials: 316 SS, PTFE, brass.
Accuracy: 2% of reading, ± 0.5 psi.
Compensated Temperature Range: 14 to 140°F (-10 to 60°C).
Pressure Hysteresis: $\pm 0.25\%$ FS.
Pressure Range: See chart.
Process Temperature Limits: -4 to 185°F (-20 to 85°C).
Display: 5" Gorilla® glass 3, touch screen, 1280x720.
Resolution: 0.01 psi.
Power Connections: Two 1/4" male NPT.
Power Requirements: CR2050 or CR2032 lithium battery, user replaceable.
Weight: 2 lb (907 g).
Agency Approvals: CE, FCC.

MODEL CHART

| Model | English Range | Metric Range | Maximum Pressure | Available Engineering Units |
|-------------------------|------------------------------|----------------------------------|--|---|
| 490W-6-HKIT | 0 to 50 psi, 0 to 200 psi | 0 to 344.7 kPa, 0 to 1379 kPa | 100 psi (6.89 bar), 400 psi (27.58 bar) | psi, ft w.c., in w.c., Pa, kPa, hPa, cm w.c., mm w.c. |
| 490W-6-HKIT-NIST | 0 to 50 psi, 0 to 200 psi | 0 to 344.7 kPa, 0 to 1379 kPa | 100 psi (6.89 bar), 400 psi (27.58 bar) | psi, ft w.c., in w.c., Pa, kPa, hPa, cm w.c., mm w.c. |

REPLACEMENT TRANSDUCERS

| | | | | |
|-----------------|--------------|-----------|-----------|---|
| A-490W-1 | 0 to 15 psi | 1.034 bar | 30 psig | psi, ft w.c., in w.c., Pa, kPa, hPa, cm w.c., mm w.c. |
| A-490W-2 | 0 to 30 psi | 2.069 bar | 60 psig | psi, ft w.c., in w.c., Pa, kPa, hPa, cm w.c., mm w.c. |
| A-490W-3 | 0 to 50 psi | 3.447 bar | 100 psig | psi, ft w.c., in w.c., Pa, kPa, hPa, cm w.c., mm w.c. |
| A-490W-4 | 0 to 100 psi | 6.895 bar | 200 psig | psi, ft w.c., in w.c., Pa, kPa, hPa, cm w.c., mm w.c. |
| A-490W-5 | 0 to 500 psi | 34.47 bar | 1000 psig | psi, ft w.c., in w.c., Pa, kPa, hPa, cm w.c., mm w.c. |
| A-490W-6 | 0 to 200 psi | 13.79 bar | 400 psig | psi, ft w.c., in w.c., Pa, kPa, hPa, cm w.c., mm w.c. |

ACCESSORIES

| Model | Description |
|---------------------|--|
| A-HKIT-500 | Piercing gage adapter, 1/8" dia x 1-1/2" length (2 per kit) |
| A-HKIT-500XL | Piercing gage adapter, 1/8" dia x 3" length (2 per kit) |
| A-HKIT-510 | Piercing gage adapter, 1/16" dia x 1-1/2" length (2 per kit) |

USA: California Proposition 65
 ⚠ WARNING: Cancer and Reproductive Harm - www.P65Warnings.ca.gov

Gorilla® is a registered trademark of Corning, Incorporated